

COMPACT

Infrared Drying Systems

PERFORMANCE FEATURES

- Ease of Loading Garments: ✓GOOD
- Curing Capacity: ✓GOOD
- Curing Control: ✓GOOD

PRODUCT FEATURES

- Production up to 72 Pieces / Hr
- Compact Size
- Wide 20" (51cm) Belt
- Powerful Panel (2000 Watt, 115v or 3000 Watt, 230v)
- Large Heat Panel
- Adjustable Belt Speed
- Adjustable Oven Doors
- Double Wall Construction
- Power Exhaust



The Compact Dryer enables you to produce professional, long lasting images even with a limited space or budget. The Wide

20" (51 cm) belt facilitates garment loading while the large and powerful IR heat panel helps achieve fast belt speeds to cure up to 72 pieces per hour. The double wall construction and adjustable oven doors retain oven heat while the power exhaust helps remove fumes from your shop. This dryer handles a wide variety of imprints, caps, jackets, sweats, and transfers just to name a few.

Simple controls provide versatile curing and a high degree of reliability.

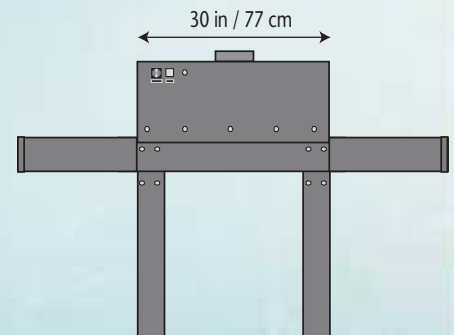
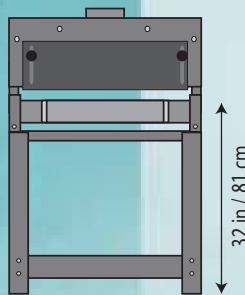
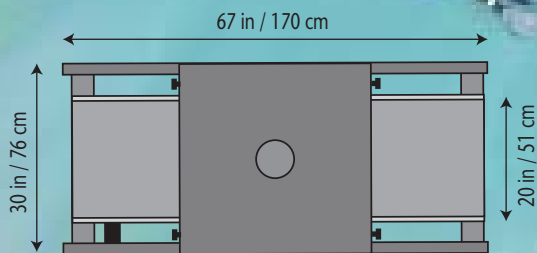

PART	DESCRIPTION	POWER
11208	COMPACT CD205, CONVEYOR DRYER 20"X5.5' (51cm x 1.7m)	115V, 1 Phase, 50-60Hz, 2000Watts, 17Amps
11209	COMPACT DRYER CD205, 20"X5.5' (51cm x 1.7m)	220-240V, 1 Phase, 50-60Hz, 3000Watts, 14Amps